

LEONARDO

© JUAN PABLO CRUZ 2002

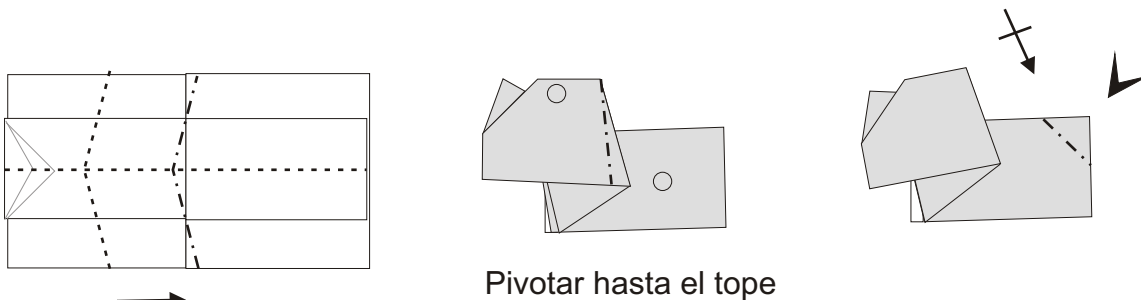

Cerrar siguiendo las marcas

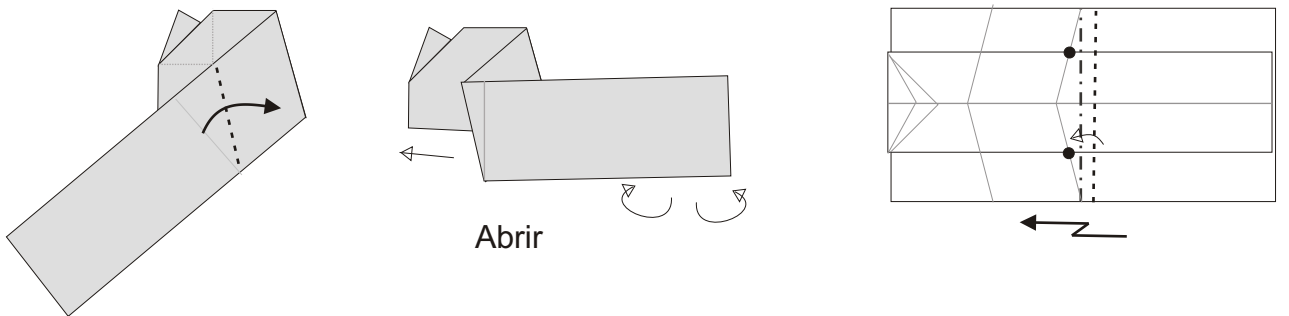
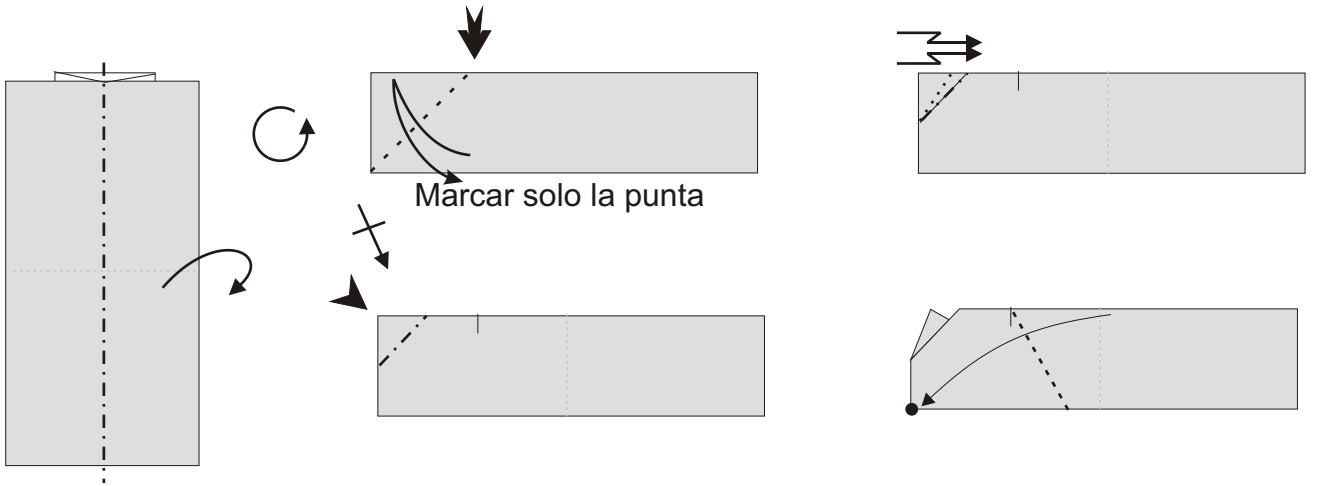
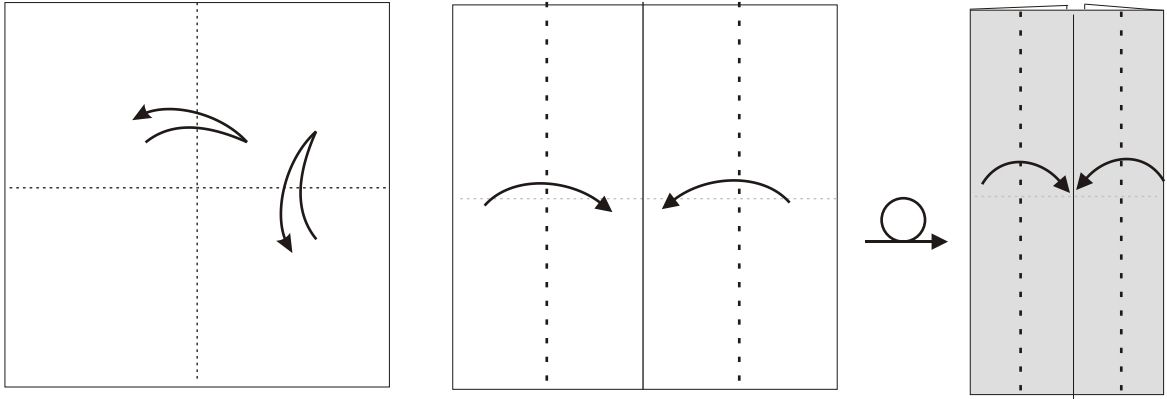
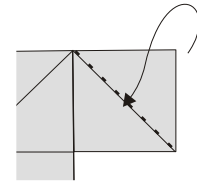
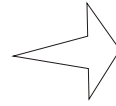
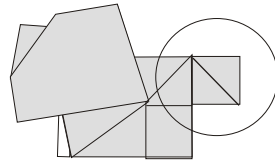
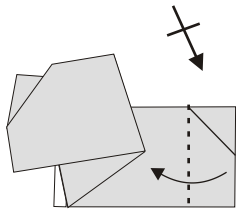

Pliegue valle, metiendo el papel en el bolsillo

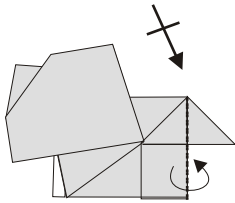

Invertir pliegue

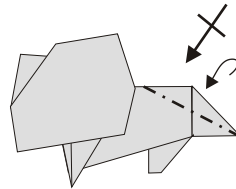
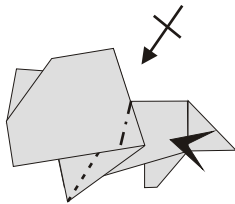
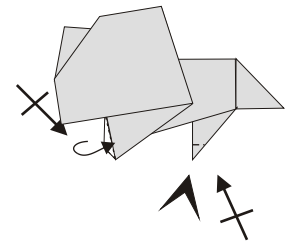
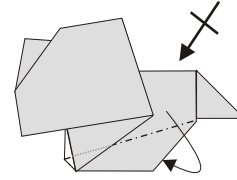
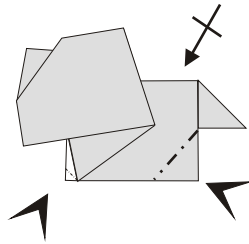

En uno de los lados plegar con la parte central

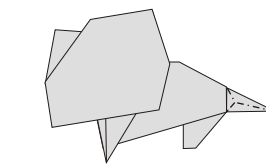

Aplastar y dar forma

